

## Features

- Stronger signal strength
- Increased electrical noise resistance
- Utilizes standard electrical wiring - retrofits easily in existing homes
- Compact and pleasing packaging

## UPB Benefits

- Higher reliability
- Lower system cost
- Individual home selective (no crossover/interference from adjacent homes)
- Easily configurable

## Applications

- Appliance control functions for non-switched outlets
- Control appliances from remote locations within the home
- Create appliance and lighting scenes within the entire home
- Control functions based upon time/event programming when installed with TIM-01 UPB Timer or Web Mountain NetPlace server



The **AM-02-A UPB Plug-in Appliance Module** provides appliance and fluorescent lighting control throughout the home.

The appliance module plugs into a standard AC outlet and the appliance to be controlled is plugged into the controlled outlet at the bottom of the module. The controlled module must have a 2-prong plug—the AM-02-A does not support grounded plugs (use the AM-01 with grounded plugs). The appliance can be manually controlled through the use of a wall-mounted or multi-button controller unit. When connected to the Web Mountain NetPlace server, the module can be controlled manually, remotely, or by the time/event programming within the server.

The key to the appliance module's function is the Universal Powerline Bus technology for communication applications. Use of standard electrical wiring for communication transmission is possible due to lower noise levels, stronger signal strength and improved reliability surpassing technologies such as X-10, CeBus and others. UPB technology also allows enough individually addressable devices to control the largest residential environment—usually without the need for phase coupling and without affecting or being affected by adjacent home environments.

**NOTE:** To assure consistently reliable operation, we recommend a UPB phase coupler for every installation.

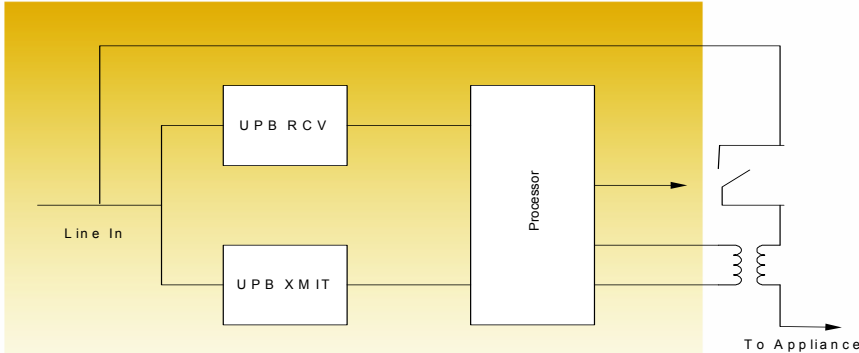

### Installation

Plug the module into a wall outlet, then plug the appliance or lamp to be controlled into the outlet on the bottom of the module.

Specifications	
Model Name	2-Prong Appliance Module
Model Number	AM-02-A
Case	2-Prong plug-in module
Dimensions	Approx. 1.125"D X 2.25"W X 2.75"H
Net Weight	3 oz.
Protocol	UPB
Addressing	250 network codes; 250 individual device codes
Input Voltage	120V AC +/- 10%, 60 Hz, 2 prong
Output	120V AC, switched output, 2 prong
Load Type	Appliances, fluorescent lighting requiring on / off current
Power Measurement	Allows measurement of power delivered to load (requires Web Mountain NetPlace server)
Maximum Load Delivered	Max 12 A
Certifications	UL 1950, FCC Part 15, Class B
Operating Temperature	0° to +50° C, 30° to 120° F
Warranty	2 years

Web Mountain Technologies, LLC  
 13882 E. Grand Ave., Aurora, CO 80015  
 info@webmtn.com      www.webmtn.com

Sales Ph: 720-207-9174  
 Office Ph: 303-627-1856  
 Fax: 303-627-7665

Copyright 2000-2006 Web Mountain Technologies, LLC. All rights reserved. NetPlace and LanBuilder are trademarks of Web Mountain Technologies, LLC. X-10 is a registered trademark of X-10 PRO. Windows is a trademark of Microsoft Corporation. Linux is a trademark of Linus Torvalds. Apple is a trademark of Apple Computer, Inc. Netscape is a registered trademark of Netscape Communication Corporation. All other products and company names are trademarks of their respective holders.